

## **The Application of Visual Basic Computer Programming Language to Simulate Numerical Iterations**

Abdulkadir Baba HASSAN, Matthew Sunday ABOLARIN, Onawola Hassan JIMOH

*Department of Mechanical Engineering, Federal University of Technology, Minna*  
[abdulkadir\\_hassan2003@yahoo.com](mailto:abdulkadir_hassan2003@yahoo.com), [abolarinmatthew@yahoo.com](mailto:abolarinmatthew@yahoo.com), [honawola@yahoo.com](mailto:honawola@yahoo.com)

### **Abstract**

This paper examines the application of Visual Basic Computer Programming Language to Simulate Numerical Iterations, the merit of Visual Basic as a Programming Language and the difficulties faced when solving numerical iterations analytically, this research paper encourage the uses of Computer Programming methods for the execution of numerical iterations and finally fashion out and develop a reliable solution using Visual Basic package to write a program for some selected iteration problems.

### **Keywords**

Simulation, Algorithm, Constrain, Integration, errors, Runge-Kutta, Euler, Improved Euler, Predictor-Corrector, Newton-Raphson, Langragian Interpolation Polynomial, Visual Basic, programming Language, debug, FORTRAN, COBALT, PASCAL, DBASE, C-Language JAVA, Analytically, UNIX Operating system

### **Introduction**

Computer Simulation is a powerful alternative approach to solve numerical iteration using a high level language of interest. Simulation is a very useful research tool and is a legitimate, disciplined approach to scientific investigation and its value needs to be

recognized and appreciated. Simulation analysis offers a variety of benefits; it can be useful in developing theory and in guiding empirical work. It can provide insight into the operation of complex systems and explore their behavior. It can examine the consequence of theoretical arguments and assumptions generate alternative explanations and hypothesis, test the validity of explanations

Numerical analysis is concern with the mathematical derivation description and analysis of methods of obtaining numerical solution of mathematical problems with little or no error resulting from approximation. It's can also be referred to as that branch of applied mathematicians which studies the methods and algorithms to find (approximate) numerical solutions to various mathematical problems using a finite sequence of arithmetic and logical operation. It is a process of repeating a set of instruction, a specified number of times until a specific result is achieved. The invention of modern technology has greatly makes life easy for scientist & Engineering with invention of computer machines of various specifications, design speed and the development of various computer application programming languages which helps in writing and development of programs that can be used to solve quite a number of numerical iterations. Scientist and Engineering are not only interested in the formulation of equations but also design and model various methods for which problem can be solved. Analytical techniques is consider to be time wasting and there is a limit to this in terms of solving a complex mathematical iterations, however application of computer can do even more complex forms of any given formula and equations and this is the focus of this paper.

Conte S.D (1965), did an excellent job on numerical analysis and programming aspect of it when they make uses of Fortran IV programming language they make a comparison between analytical method of solving numerical iterations and programming method of solving numerical iterations and came up with a conclusion that programming method of solving numerical iterations using computer is faster than using analytical method and safe time with a very negligible errors or no errors incurred at all.

Haggerty G.B(1972), view that more often that not all numerical analysis are oriented toward a mathematical treatment of the subject, he attempt to bridge this gap without neglecting the mathematical aspect, so the entire content of his work contains abundance of flow chart and programs with output ranging from simple to rather sophisticated type of problems. He also used FORTRAN IV programming languages for the algorithms.

Above all, these researchers make use of FORTRAN IV programming language which is a text based language. Text based language do not allow the users to work directly with graphics and this is one disadvantage why the use of FORTRAN IV programming language is not considered for use in this research work, rather visual basic programming language is considered for use.

Visual basic programming language is one of the most widely used high level language today because of its advantages.

### **Types of programming language**

Hundreds of high level languages have been developed and designed among these are BASIC which is (Beginner, All purpose Symbolic Instruction Code) FORTRAN, COBALT, PASCAL, DBASE, C-Language JAVA etc.

FORTRAN (Fortran Translator) was developed by IBM Corporation between 1954 and 1957 to be used for scientific and engineering application that require complex mathematical computation but it is a text based programming language.

Dennis Richie in 1972 at Bell laboratories developed a C- programming language, C language is a very popular package among the computer user, it was first used to develop the UNIX Operating system. C<sup>++</sup> is an extension of C, developed by Bjarne Stroustrup in the early 1980's at Bell laboratories. C<sup>++</sup> provides a number of features that "spruce up" the C language has the capabilities for doing so called object-oriented programming (OOP) Many people believe that (OOP) can greatly improve the software development process C<sup>++</sup> has become the dominant system implementation language.

Java was developed by SUN Micro system and released in 1995. Java is based on C and C<sup>++</sup> and incorporates a number of features from other object oriented language. Java includes extensive libraries for doing multimedia, networking, multi reading graphics data base access and much more. Microsoft version of Java is called visual J<sup>++</sup> many people believe that Java and visual J<sup>++</sup> will be the most significant long-term competitor to Visual Basic.

### **Design analysis**

The design analysis involved developing, writing of program and the installation application package that is compatible with the program that have been developed and be able to run concurrently with the program already installed in the system. The application program that was considered suitable for the program is Visual Basic version 6.

### ***Methodology***

The techniques used for this project includes consultations of relevant text books that treated numerical iterations and some programming text books that treated Visual Basic and other mathematical text books.

### ***Evolution of visual basic***

Visual basic is derived form the BASIC programming languages, it is a Microsoft window programming language, visual basic program are created in an integrated development environment (IDE), which allows the programmer to create run and design visual basic programs conveniently it's also allow a programmer to create working programs in a fraction of time that normally takes to code programs without using IDEs. The wide spread use of BASIC Language with various types of computer (sometimes called hardware platform) led to many enhancement to the languages with the development of Microsoft windows graphical user interface (GVI) in the late 1980's and the early 1990's, the natural evolution of basic was visual basic which was created by Microsoft corporation in 1991.

Visual basic is the worlds most widely use RAD language, (Rapid Application Development (RAD) is the process of rapidly creating an application. Visual Basic provide a powerful features such as graphical user interface, events handling assess to Win 32 API, object-oriented features, error handling, structured programming and much more.

Not until Visual Basic appeared, developing Microsoft windows based application was a difficult and cumbersome process. Visual basic greatly simplifies window application development.

### ***The advantages of visual basic programming language***

Quite a number of programming languages are text based and text based languages which do not allow user to work directly with graphics but visual basic is a graphical based

language which allows user to work directly with graphic. Graphical based language can be used to develop windows program quickly.

Visual Basic gives a disciplined approach to writing programs that are clearer than unstructured programs, easier to test, debug and can be easily modify.

It allows for the creation of powerful and professional looking application with less time and coding. It allows for strong typing i.e. has wide variety of input data types and support Rapid Application Development (RAD).It has a complete edifying and debugging facilities and has the ability to generate a Dynamic Link Libraries (DLL`S), it allows for easier management of document and it is easy to learn.

Visual Basic is a complete form of package for building user interface

### Theories & analysis

This a method use in obtaining a new approximate solution, it is a repeating process for obtaining a new approximate solution .This process can be carried out either analytically or by writing a programming language using a particular programming language of interest.

As early stated in this research paper Visual Basic programming language has been chosen for use. This paper is only going to consider, application of Visual Basic to solve the solutions of five different numerical iteration methods. These are Newton Raphson, Euler, Improved Euler, Runge- kutta and Lagrange's interpolation methods and this is the limit of this paper. An algorithm to look into how this program can be written has been developed which follows the patterns of the flow chart:

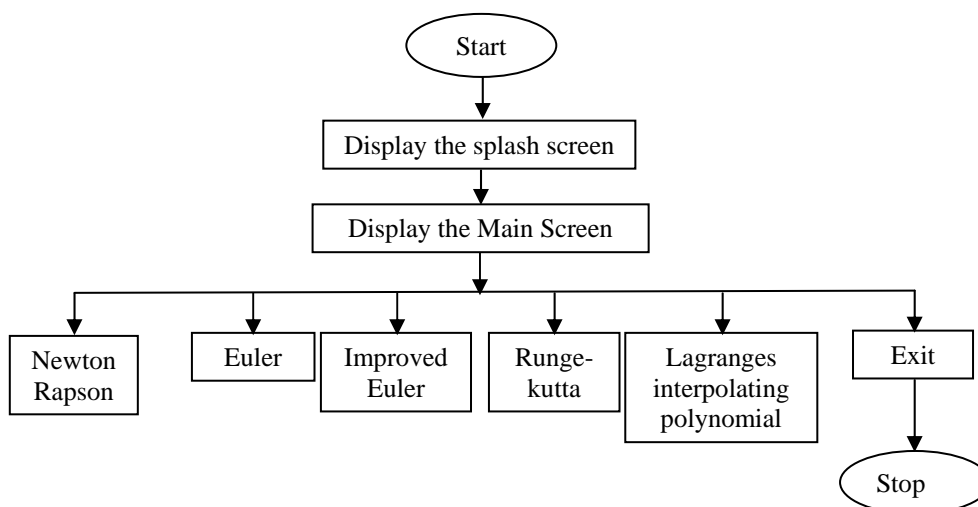
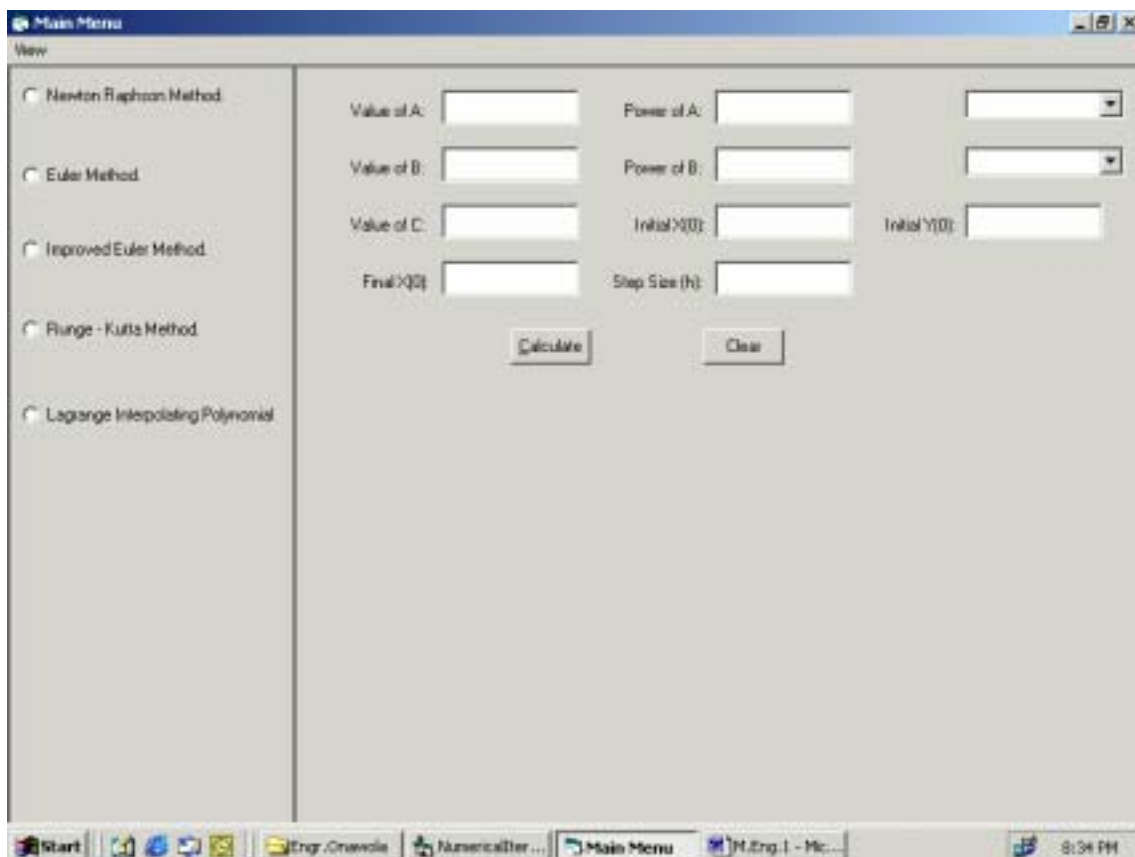
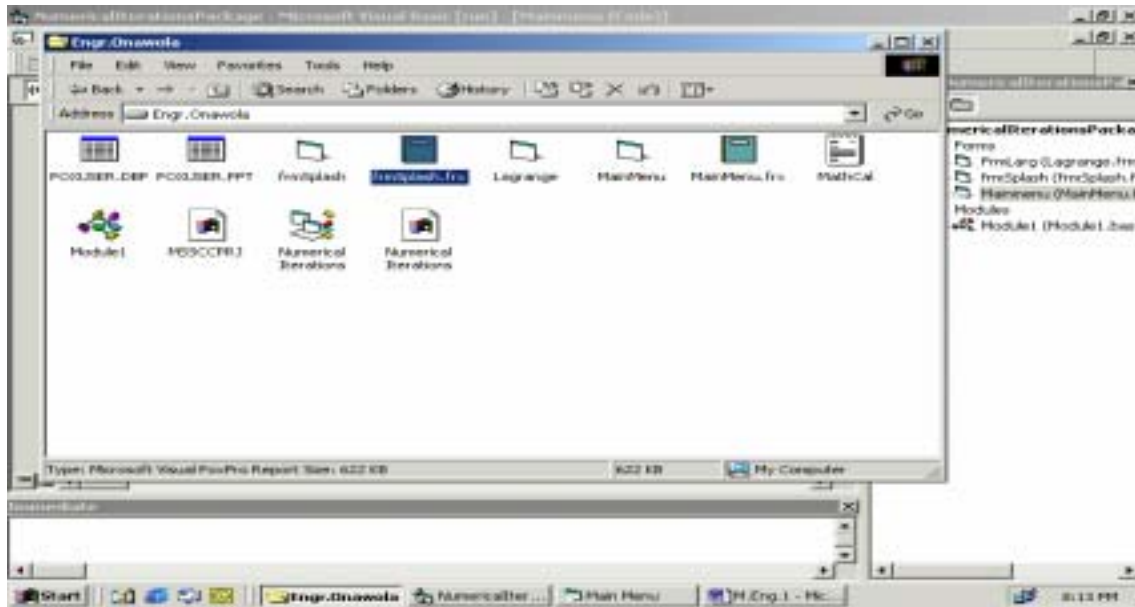
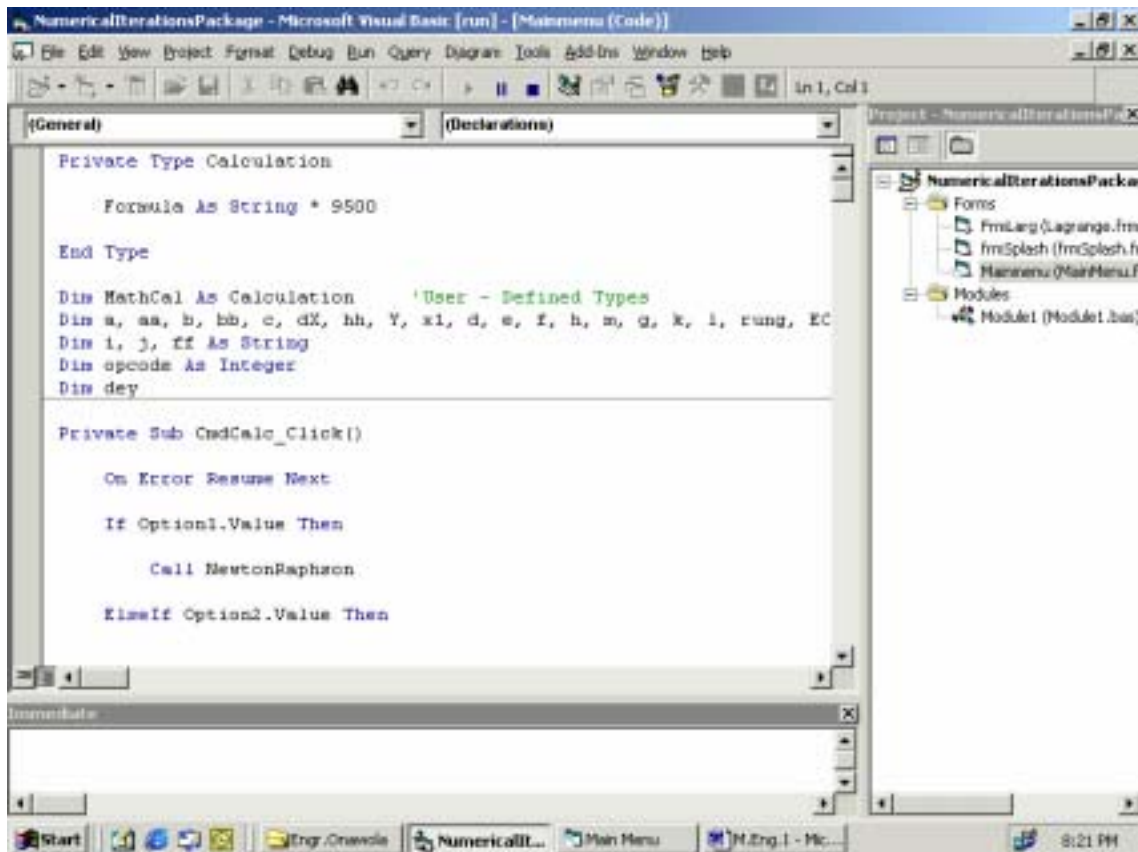

Figure 1. Flow Chart of Numerical Iterations Process

## Program design

The application program was installed in the system with the program written for each of the iteration to be implemented in the program, these are shown below:





```
Private Type Calculation
    Formula As String * 9500
End Type

Dim MathCal As Calculation 'User - Defined Types
Dim a, aa, b, bb, c, dX, hh, Y, x1, d, e, f, h, m, g, k, i, rung, EC
Dim i, j, If As String
Dim opcode As Integer
Dim dey

Private Sub CmdCalc_Click()
    On Error Resume Next

    If Option1.Value Then
        Call NewtonRaphson
    ElseIf Option2.Value Then
```

## System analysis

### *Computer system*

Computer system falls into two classes: the software system and the hardware system. The software is the collection of programs or instructions that control the operations of computer hardware. On the other hand, the Computer hardware is the physical components and devices, which make up the visible computer. Computer hardware consists of at least one computer and its peripheral devices as shown in figure 2.

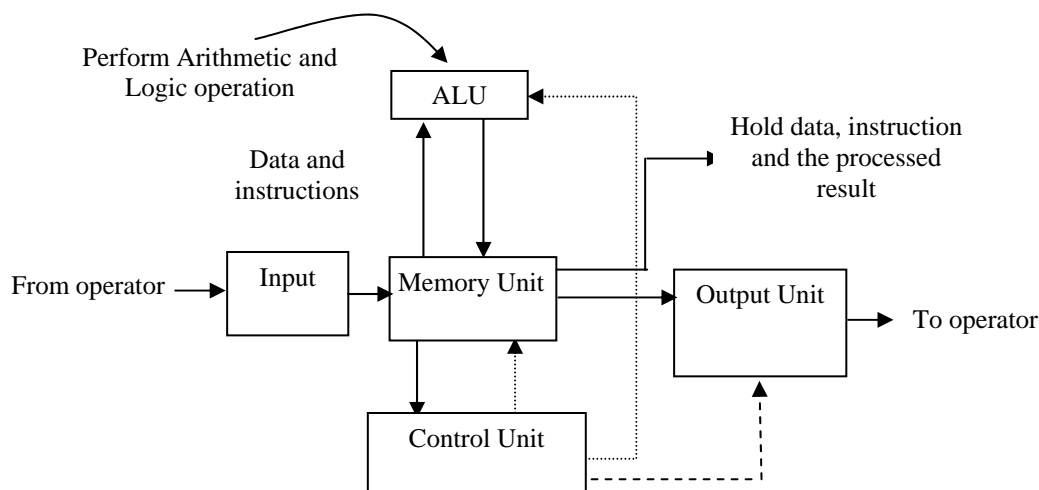

*Figure 2. Computer hardware configuration*

### *Organization of a digital computer*

A digital computer is functionally organized into the following fundamental units: -

- **Input:** The input devices read the necessary data into machine. It maintains communication between the computer and its environment by accepting communication from the devices and converting it to a form suitable for use by the rest of the computer systems. Examples of input devices include the keyboard, punched card and paper tape readers, magnetic tape readers and various manual input devices such as toggle and pushbuttons.
- **Control:** It is usually generated by the control unit of a computer to sequence the operation of the computer as well as controlling the actions of all other units such as the input store and ALU. It also controls the future operation of the controls unit itself.
- **Memory:** The memory, or storage, section of the computer consists of the devices used to store the information that will be used during the computations. The memory is also used to hold by intermediate and final results as the computer proceeds through the program. Examples of storage devices are integrated circuit memories, magnetic tape, and magnetic disks.
- **Arithmetic-Logic Unit:** This is action of the computer to transforms data by performing arithmetic and logical operation that is, it is capable of performing addition, subtraction, division, and multiplication as well as some logical operations. The ALU operates under the command of the control units, which controls the operation of the various sections and direct the flow of information among them.



- **Output:** This is used to record the results obtained by the computer and present them to the outside world. Common output devices are CRT displays, printers, card punching machines, and magnetic - tape drives etc.

In the system analysis the system will be provided with the equations other details such as initial value  $x$ , the steps and some other require input conditions as been required, specified for the equation to be iterated, with all the required data available, the user can enter the data into the computer by instructing and specify what the system should do, once this is done the system will process it, come with result which can be viewed on the screen. However there are some requirements which must be satisfied in order to achieve the best result, these are highlighted below:

- The iteration to be performed must be chosen;
- All the initial conditions must be specified;
- The system should be able to serve the purpose irrespective of where it is used provided the package and all necessary Operating System (OS) require in running the iteration is install in the system.

### *System design*

The package require to run the iterations process has been written with the Visual Basic(VB) installed into the system to be used for the execution of the iteration process it has also been tested and run with different data tested for its limit and level of its accuracy. To obtain the best possible result the input data must conform to the rules of the iteration to be implemented. Parallel approach is system adopted in the implementation of the design for the system, parallel approach is a system whereby the computer is allow to runs alongside the existing manual method. After a given time depending on the configurations and the speed of the system use in the implementation of the iteration a report from the system unit is display on the screen which can be evaluated and if the results are acceptable the system can be fully adopted.

### *Objectives of system design*

- **Efficiency:** These involve accuracy, speed and comprehensiveness of the system output.

- **Flexibly:** This is the ability of the system to adjust to the changing requirement of user. It also involves portability of system.
- **Practicability:** This is the ability of the System to be able to withstand long period of time operation by the user
- **Security:** The act of applying security for the protection of the data and it involve hardware reliability. A system analysis needs to have a workable security system to protect the system from damage error and by unauthorized user

### *System requirement*

#### *Software Specifications*

The soft requirement for the system includes:

- Window XP operating System
- Mcafee Antivirus Package
- Microsoft Visual Basic Ver 6.0

#### *Hardware Specifications*

The hardware specifications for this project work are stated as follow:

- Pentium Motherboard
- Processor Intel 333 HZ
- Memory (RAM): 128MB
- Hard disk 5GB
- Monitor SVGA 17 Inch
- Printer HP 1100 Laser jet
- An enhanced Key board

### *System evaluation*

This program was developed to eliminate the problem face in the analytical method of solving numerical iteration which aims at providing the following:

- Accuracy;
- High Speed;
- High storage capacity;
- Good efficiency;
- Reliability;

- Reduce errors;
- Adequate security for the program.

### **Results & Discussions**

Having stated the formulae to be used in the execution of the iteration processes for only five selected mathematical iterations, a program written in Visual Basic version 6.0 languages was successfully run in a PC system, with this package, one can slot in any value provided the value falls within the validity of the simulation model of the program. The program has the capability to accept, run, perform, execute and give the final answers to numerical iteration method adopted.

### **Conclusion**

Computer Simulation is a useful research tool that opens up new techniques for solving numerical iteration problems. It saves time and reduces errors to its minimum level as compare with analytical approach which have limiting point. Solving numerical iterations using Visual Basic is more convenient to use in the simulation of numerical iterations and is less prone to errors.

### **Recommendation**

It is recommended that a more elaborate and extensive research be fashioned out using Visual Basic programming language to be used in the execution of a very complex iteration problems which is expected to surpass what is in this research work, due to the parallel approach method that were adopted in the system, it is also recommended that for the running of the system that total eradication of manual operation is not possible and also the user can not operate the system without prior knowledge of the manual method

## References

- [1] Axelrod R., *Advancing the Art of Simulation in the Social Science*, In Rosaria Conte, Rainer Hegselmann, and Pietro Terna (Eds.), *Simulating Social Phenomena*, Berlin: Springer, 1997.
- [2] Edwards C. H., David E. P., *Calculus and Geometry*, 3<sup>rd</sup> Ed. Prentice-Hall Inc, New Jersey, 1990.
- [3] Conte S. A., Boor C. D., *Elementary Numerical Analysis*, An Algorithmic Approach, McGraw-Hill Book Company, New York, 1965.
- [4] Fatunla S.O., *Numerical Methods for Initial Value problems in Ordinary Differential Equations*, Academic Press, Inc, pp. 78-79, 1988.
- [5] Hamming R. W., *Numerical Methods for Scientific and Engineers*, McGraw-Hill Book Company, New York, 1962.
- [6] Harrison J. R., *Dominant Coalition Dynamics, The Politics of Organizational Adaptation and Failure*, Paper presented at the International Conference on Computer Simulation and the Social Science, Cortona, Italy, 1997.
- [7] Ronald J. H., James J. R., *Calculus with Applications*, D.C. Health and Company, Canada, 1990.
- [8] Trauls J. F., *Iterative Methods for the Solution of Equations*, Prentice-Hall Inc, Englewood Cliffs, New Jersey, 1967.